

Limited 90-Day Warranty

iHome Products, a division of SDI Technologies Inc. (hereafter referred to as SDI Technologies), warrants this product to be free from defects in workmanship and materials, under normal use and conditions, for a period of 90 days from the date of original purchase.

Should this product fail to function in a satisfactory manner, it is best to first return it to the store where it was originally purchased. Should this fail to resolve the matter and service still be required by reason of any defect or malfunction during the warranty period, SDI Technologies will repair or, at its discretion, replace this product without charge (except for a \$7.00 charge for handling, packing, return UPS/postage, and insurance). This decision is subject to verification of the defect or malfunction upon delivery of this product to the Factory Service Center listed below. The product must include proof of purchase, including date of purchase. The fee for service without proof of purchase is

\$15.00. Before returning this product for service, please first replace the batteries (if applicable) with fresh ones, as exhausted or defective batteries are the most common cause of problems encountered.

If service is still required:

1. Remove the batteries (if applicable) and pack the unit in a well padded, heavy corrugated box.
2. Enclose a photocopy of your sales receipt, credit card statement, or other proof of the date of purchase, if within the warranty period.
3. Enclose a check or money order payable to the order of SDI Technologies, for the sum of \$7.00 (\$15.00 without proof of purchase).
4. Send the unit prepaid and insured, to the Factory Service Center listed below.

**Consumer Repair Department
SDI Technologies Inc.
1330 Goodyear Drive
El Paso, TX 79936-6420**

Disclaimer of Warranty

NOTE: This warranty is valid only if the product is used for the purpose for which it was designed. It does not cover (i) products which have been damaged by negligence or willful actions, misuse or accident, or which have been modified or repaired by unauthorized persons; (ii) cracked or broken cabinets, or units damaged by excessive heat; (iii) damage to digital media players, CD's or tape cassettes (if applicable); (iv) the cost of shipping this product to the Factory Service Center and its return to the owner.

This warranty is valid only in the United States of America and does not extend to owners of the product other than to the original purchaser. In no event will SDI Technologies or any of its affiliates, contractors, resellers, their officers, directors, shareholders, members or agents be liable to you or any third party for any consequential or incidental damages, any lost profits, actual, exemplary or punitive damages. (Some states do not allow limitations on implied warranties or exclusion of consequential damages, so these restrictions may not apply to you.) This warranty gives you specific legal rights, and you may also have other rights which vary from state to state.

Your acknowledgement and agreement to fully and completely abide by the above mentioned disclaimer of warranty is contractually binding to you upon your transfer of currency (money order, cashier's check, or credit card) for purchase of your SDI Technologies product.

**Questions? Visit www.ihomeaudio.com
For any other questions: 1-800-288-2792 Toll Free
©2008 SDI Technologies, Inc. All Rights Reserved.**

iHome

Model iHM20
**the folding micro
stereo system for your iPod nano**

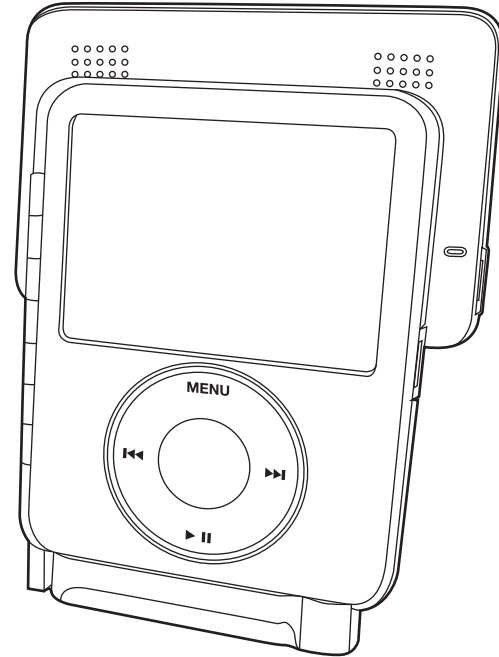

QUESTIONS? Visit www.ihomeaudio.com

IMPORTANT Read before proceeding

If you have any questions regarding the operation or use of this product, please visit www.ihomeaudio.com to view answers to frequently asked questions.

To learn more about this and other iHome products, please visit us online at www.ihomeaudio.com

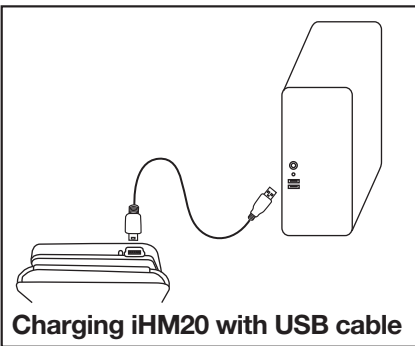

Charging iHM20 with USB cable

NOTE: THIS UNIT DOES NOT CHARGE IPOD NANO

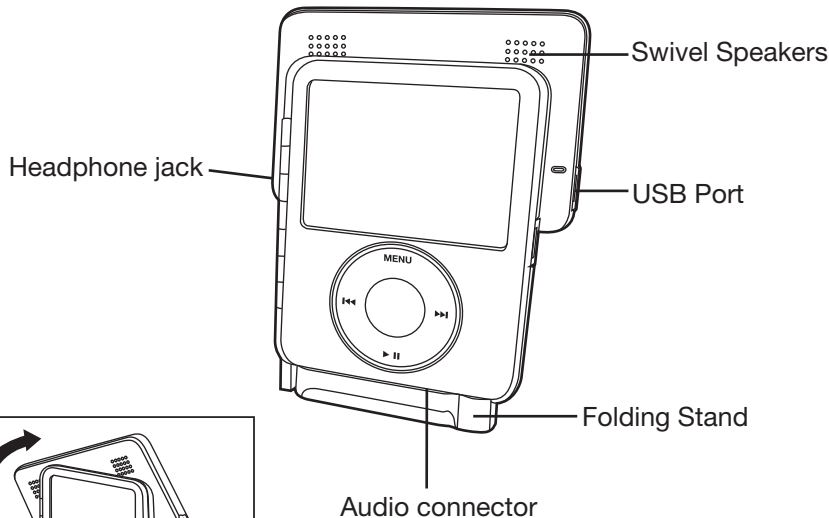
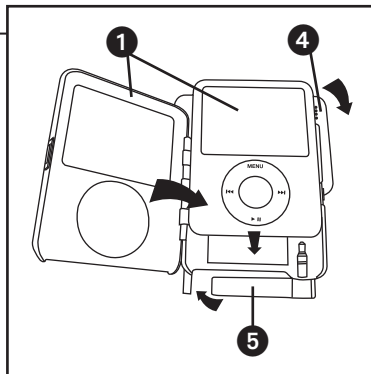

Swivel speaker and fold out the stand to listen to your nano

NOTE: ADJUST NANO VOLUME TO AVOID DISTORTION

Using the iHM20

Thank you for purchasing the iHM20. Designed to work exclusively with the 3rd generation iPod nano, this system provides portable stereo audio that fits in your pocket. Please read the instructions carefully before operating the unit and keep for future reference.

Recharging the iHM20 Battery

The iHM20 has a built-in rechargeable battery to power the speakers. When the blue power light on the unit fades or goes out, it's time to recharge the battery.

To recharge the battery, connect the USB cable (included) to the USB port on the iHM20 and connect the other end to a powered USB port on your computer. A red light will appear while the unit charges and turn off when the unit is charged.

This unit does not charge the nano.

Listening to your 3rd generation iPod nano

1. Snap open the clear plastic door on the unit. Carefully slide your 3rd generation iPod nano into place, lining up the headphone jack on the nano with the audio plug at the base of the unit.
2. Turn on your iPod nano and press Play.
3. Close the door on the unit.
4. Swivel the speaker housing into the open (upright) position to turn ON the iHM20. Set the desired volume on your nano.
5. Fold back the stand arm at the bottom of the unit for upright listening.
6. To turn the unit OFF, swivel the speaker housing to the closed position.

Listening with Headphones

The iHM20 has a headphone jack on the bottom left of the speaker housing so you can listen to your 3rd gen nano privately even while it's protected in the iHM20 case. Just connect headphones to the headphone jack and play your nano as usual. The iHM20 speakers are disabled when the headphone jack is in use.

Maintenance

- Place the unit away from sources of direct sunlight or excessive heat.
- Protect your furniture when placing your unit on a natural wood and lacquered finish.
- Clean your unit with a soft cloth moistened only with mild soap and water. Stronger cleaning agents, such as Benzene, thinner or similar materials can mar the surface.